

The Solid-State Bird

WHISTLES AND WARBLES LIKE A CANARY

BY JOHN S. SIMONTON, JR.

IF YOU LIKE the sweet, warbling song of a canary but don't dig that cage to be cleaned, try this electronic bird—a real solid-state, battery-operated singer. When turned on, the bird whistles down-scale for a few seconds, breaks into a warble, and, after several seconds, shuts off—only to start again automatically in a few more seconds.

The bird's circuit, shown schematically in Fig. 1, is deceptively simple in appearance. The most immediately obvious feature is an astable multivibrator made up of Q1, Q2, and their associated base timing circuits. Not so obvious is the blocking oscillator whose principal components are Q2, C2, and T2. The latter produces the warble.

When power is turned on, the bias circuits cause Q1 to be turned on and Q2 off. Capacitor C1 is initially discharged; but, as it begins to charge up through R3,

Q2 becomes forward biased by the current through T1 and R4. Eventually, the point is reached where Q2 acts as a blocking oscillator, and Q1 follows it because of coupling through C5.

During this oscillation, C1 is charged in a negative direction as a result of the half-wave rectification provided by Q2 (which is reverse biased during negative half cycles). Since the charging current is heavy at first and tapers off as C1 charges, the inductance of T1 goes from a low value to a high one because of the decreasing core saturation. The output tone then decreases in pitch.

Capacitor C1 goes rapidly negative with respect to ground, and its effect in the biasing of Q2 is replaced by the action of the oscillator itself during the positive half cycles and the charging current through C4 during the negative half cycles. Eventually, C4 charges to the

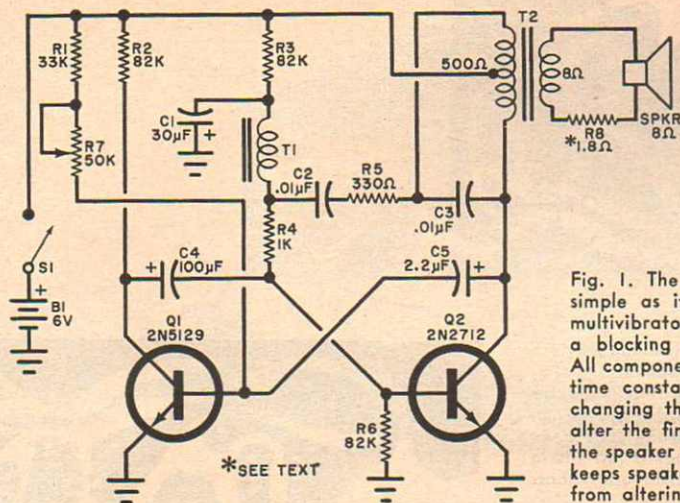

Fig. 1. The circuit is not as simple as it looks. Besides a multivibrator, there is also a blocking oscillator. All components are part of one time constant or another, so changing the value of one will alter the final sounds. Note the speaker damping (R8) that keeps speaker acoustic loading from altering the oscillator.

PARTS LIST

- B1—6-volt battery (4 AA cells in series)
- C1—30- μ F, 6-volt electrolytic capacitor
- C2, C3—0.01- μ F disc capacitor
- C4—100- μ F, 6-volt electrolytic capacitor
- C5—2.2- μ F, 6-volt electrolytic capacitor
- Q1—2N5129 transistor
- Q2—2N2712 transistor
- R1—33,000-ohm, $\frac{1}{2}$ -watt resistor
- R2, R3, R6—82,000-ohm, $\frac{1}{2}$ -watt resistor
- R4—1000-ohm, $\frac{1}{2}$ -watt resistor
- R5—330-ohm, $\frac{1}{2}$ -watt resistor
- R7—50,000-ohm trimmer PC potentiometer

- R8—1.8-ohm, $\frac{1}{2}$ watt resistor
 - S1—Spst slide or toggle switch
 - T1—10K:2K driver transformer (Lajayette TR-98, 99F61269 or similar)
 - T2—500-ohm CT:8-ohm output transformer (Lajayette TR-116, 99F61293 or similar)
 - Misc.—8-ohm speaker, plastic case, battery clips, wire solder, etc.
- Note—The following are available from PAIA Electronics, PO Box 14359, Oklahoma City, OK 73114: etched and drilled PC board, \$1.25; complete kit less batteries and case, \$6.95; both postpaid in USA.

point where its contribution to the Q2 biasing is small and the base/emitter junction of Q2 is reverse biased during a larger portion of each succeeding cycle. At some point, the blocking oscillator starts to "squegg," that is, the charge ac-

cumulated on C2 during negative half cycles is large enough that Q2 is turned off completely until the charge leaks off. Once the charge has leaked off, Q2 can oscillate once more. This charge-discharge cycle happens so rapidly that the audio

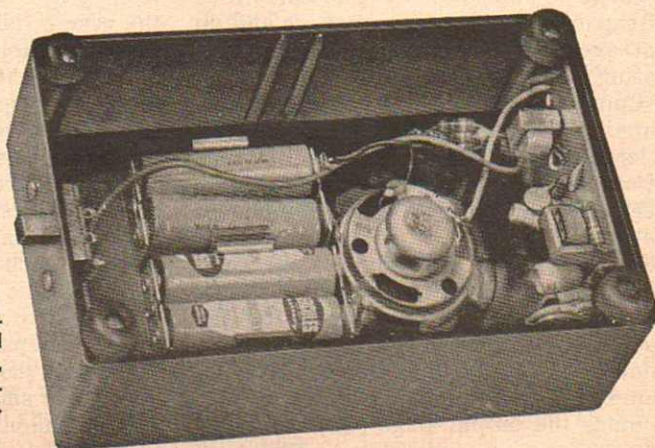

In prototype mounting arrangement, the speaker is mounted at the "bottom" of the box, while the "top" is left open. The rubber feet fit in cover.

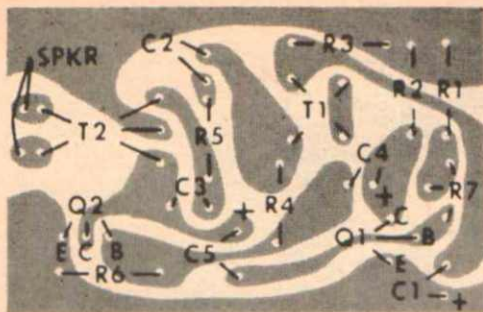
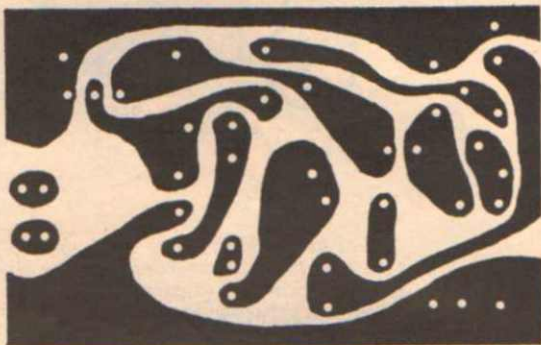

Fig. 2. Actual size foil pattern (right) and component installation (above). Note that miniature transformers must be used on this small PC board. It has been laid out so that it just fits in 6" x 3" x 2" plastic utility box.



tone generated sounds like a warbling bird. Finally, C4 discharges to the point where it makes no contribution to the biasing of Q2 and the latter turns off. With Q2 off, Q1 turns on and the cycle repeats.

Construction. Layout of the bird is not critical and any method of construction may be used. If you want to use a printed circuit board, the foil pattern and layout in Fig. 2 can be used. During assembly, be sure to observe the polarities of capacitors and semiconductors and do not overheat the components when soldering.

Component values are important. The circuit will work with the normal 10% tolerance of resistors and 20% tolerance of capacitors, but variations of any larger degree will throw it off. Every component determines some type of time constant, so if you change the value of one component, be prepared to change the rest.

Install leads on the board for the speaker and battery, making them long enough to reach when the board is located in the selected cabinet.

Since the output stage (Q2) works di-

rectly into the speaker without any buffering, any change in the speaker loading will be reflected back into the oscillator circuit, resulting in a change in the sound. This means that the selected enclosure (for board, batteries, and speaker) must have no resonant or antiresonant peaks. Resistor R8 is included as an option to isolate (partially) the speaker from the circuit.

The prototype was built in a conventional 6" x 3½" x 2" plastic case with the front cover not used. In the bottom of the case a hole was cut for the speaker. Make the hole slightly smaller than the diameter of the speaker and cement the speaker to the case behind the hole. Four rubber feet were attached to the holes on the opposite side (where the front panel was). The battery clips were mounted on the same side as the speaker with the PC board cemented to one wall and the power switch on the other wall.

The plastic case should be dressed up with a toy bird to complete the illusion. There are many garden supply houses that stock colorful stuffed birds—some even have small wood or metal cages to enclose the bird. ♦